



This manual is for reference and historical purposes, all rights reserved.

This page is copyright© by M. Butkus, NJ.

This page may not be sold or distributed without the expressed permission of the producer

I have no connection with any camera company

On-line camera manual library

This is the full text and images from the manual. This may take 3 full minutes for the PDF file to download.

If you find this manual useful, how about a donation of \$3 to: M. Butkus, 29 Lake Ave., High Bridge, NJ 08829-1701 and send your e-mail address so I can thank you. Most other places would charge you \$7.50 for a electronic copy or \$18.00 for a hard to read Xerox copy.

This will allow me to continue to buy new manuals and pay their shipping costs.

It'll make you feel better, won't it?

**If you use Pay Pal or wish to use your credit card,
click on the secure site on my main page.**

Canon

EOS

REBEL / REBEL
Ti Ti

DATE

300V / 300V DATE



English

E

INSTRUCTIONS

Thank you for purchasing a Canon product.

The EOS REBEL Ti (DATE) / 300V (DATE) is a very compact autofocus, single-lens reflex camera. It can be used for a wide variety of subjects and situations with fully automatic and user-controlled shooting modes. Read this Instructions and familiarize yourself with your new camera before taking pictures.

Also read "Handling Cautions" on page 4 to prevent camera malfunction and damage.



Keep this instruction booklet handy for easy reference.

Before Using Your Camera

- Before shooting an important event, be sure to take test shots to make sure the camera operates properly.
- EOS cameras have a lens mount for dedicated operation (autofocusing, exposure control, etc.) with Canon EF lenses. Using a non-Canon EF lens with an EOS camera may not result in proper camera or lens operation.

Note that the warranty does not cover any camera malfunction or damage occurring with the use of non-Canon products.

Conventions Used in this Instructions

- The  icon indicates the Main Dial.
- All operation procedures described in this booklet assume that the Command Dial is set to a mode except **< OFF >**. Before proceeding with any operation, be sure that the Command Dial is set to a shooting mode.
- Page numbers in parentheses (→page ■) indicate where you can find additional relevant information.
- The camera control icons and markings used in this booklet correspond to the actual icons and markings found on the camera. See "Nomenclature" on page 8.
- The () and () icons indicate that the respective function remains in effect for 4 and 6 sec. respectively after the button is released.

Contents

Conventions Used in this Instructions	2
Handling Cautions	4
Quick Start Guide	6
Nomenclature	8

1 Before You Start13

The things you need to do before taking pictures and the basic operation are explained.

2 Fully Automatic Shooting21

Since everything is automatic, all you do is press the shutter button.

3 User-Controlled Shooting31

Set the shutter speed, aperture, exposure compensation, AEB, and other settings as you wish.

Reference52

Basic terminology, exposure warning displays, shooting mode settings, and other information.

Symbols



The Caution symbol alerts you to actions to prevent shooting problems.



The Note symbol gives supplemental information for basic camera operation or picture-taking tips.

Handling Cautions

Camera Care and Storage

- (1) The camera is a precision instrument. Do not drop it or subject it to physical shock.
- (2) This camera is not waterproof and cannot be used underwater. If the camera gets really wet, promptly consult your nearest Canon Service Center. Wipe off any water droplets with a dry cloth. If the camera has been exposed to salty air, wipe with a well-wrung damp cloth.
- (3) Do not leave the camera in places prone to excessive heat such as in a car on a sunny day. Excessive heat can cause the camera to malfunction.
- (4) The camera contains precision electronic circuitry. Never attempt to disassemble the camera.
- (5) Use only a blower brush to blow away dust on the lens, eyepiece, mirror, focusing screen, and film compartment. Do not clean the camera body or lens with a cleaner containing an organic solvent. For stubborn dirt, consult your nearest Canon Service Center.
- (6) The shutter curtains are extremely thin. Use only a blower to clean them. Be careful not to blow air too forcefully on the shutter curtains. The shutter curtains can be easily deformed or damaged. Also, when loading and unloading film, be careful not to touch the shutter curtains.
- (7) Do not touch the electrical contacts with your fingers. Otherwise corrosion may develop on the contacts, resulting in improper camera operation.
- (8) If the camera is not to be used for an extended period, remove the battery. Store the camera in a well-ventilated, cool, dry place. During the storage period, press the shutter button to release the shutter a few times once in a while.
- (9) Avoid storing the camera in a laboratory, cabinet, etc., where corrosive chemicals are present.
- (10) If the camera has not been used for an extended period or if the camera is to be used for an important event, check the operation of all the camera controls or take it to your nearest Canon Service Center for inspection.

LCD Displays



In time, the camera's LCD panel display and the LCD display in the viewfinder may fade and become difficult to read. If this happens, have it replaced (at cost) by a Canon Service Center.

At low temperatures, the LCD display response may become slower. And at 60°C/140°F or higher temperatures, the display may blacken. In either case, the display will return to normal at room temperature.

Lithium Batteries

- (1) The camera operates on two CR2 lithium batteries. Check the battery level in the following cases (→page 14):
 - After replacing the batteries.
 - After not using the camera for an extended period.
 - The shutter stops working.
 - The camera is being used in a low-temperature environment.
 - You will be shooting an important event.
- (2) Before installing the batteries, wipe the battery contacts to remove any fingerprints and smudges. This is to prevent faulty connections and corrosion.
- (3) Never disassemble or recharge the batteries. Also, never store a battery in high-temperature places or short circuit the battery contacts or toss a battery into a fire.
- (4) Although the batteries work well even at low temperatures, battery performance may decline slightly at freezing temperatures. In such a case, keep spare batteries warm in a pocket, etc., and use and warm the batteries alternately.

How Low Battery Levels Affect Camera Operation

On the LCD panel, if the  icon blinks or it is not displayed, a proper exposure can still be obtained as long as the shutter releases. However, when the battery level is low, film advance and auto rewind might stop midway or not work at all and  may blink on the LCD panel. After the batteries are replaced with new ones, film advance will be possible and film rewind can resume by pressing the  button.

Lens Electrical Contacts

After detaching the lens from the camera, put on the lens caps or put down the lens with the rear end up to avoid scratching the lens surface and electrical contacts.

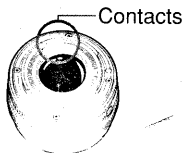

Quick Start Guide

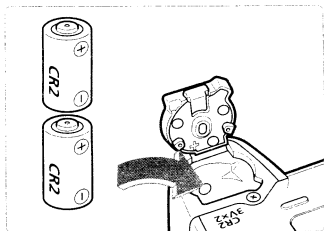

- 1 Install the batteries.**
Insert two CR2 lithium batteries as shown by the battery orientation diagram on the battery compartment cover. (→page 14)

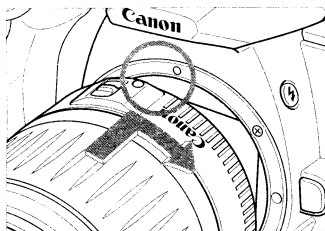

- 2 Attach a lens.**
Align the red dots on the lens and camera and turn the lens as shown by the arrow until it snaps into place. (→page 16)

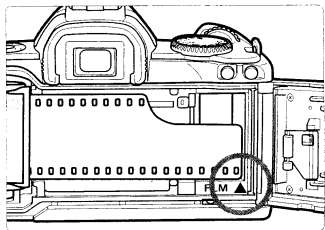

- 5 Load the film.**
Align the edge of the film with the <▲> mark, and close the back cover until it snaps shut. (→page 18)
- The film will then advance to the first frame automatically.

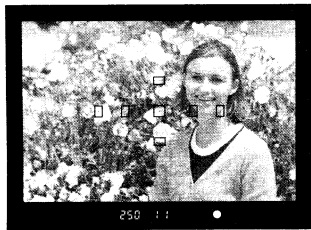

- 6 Focus the subject.**
Aim the AF point on the subject and press the shutter button halfway to auto-focus. (→page 22)
- Under low-light or backlit conditions, the built-in flash will pop-up and fire automatically. (→page 49)

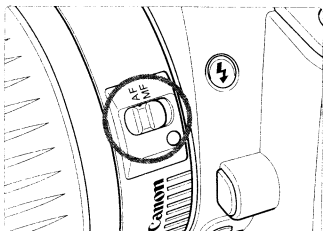

3 On the lens, set the focus mode switch to **<AF>**.

(→page 16)

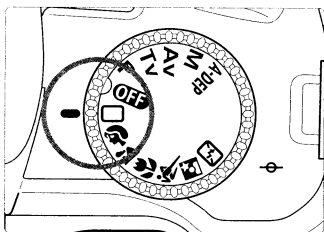

4 Turn the Command Dial to **<□>** (Full Auto).

(→page 22)

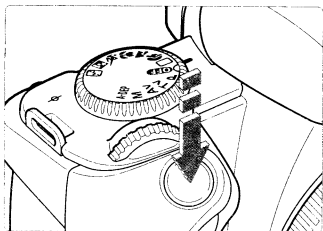

7 **Take the picture.**

Press the shutter button fully to take the picture.

(→page 17)

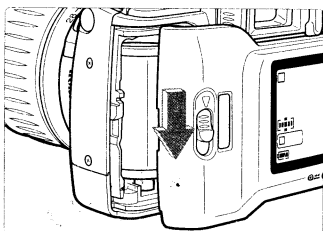

8 **Unload the film.**

At the end of the roll, the film rewinds automatically. Open the back cover to remove the film cartridge.

(→page 19)

Nomenclature

- The reference page is indicated in parentheses.
- The camera controls are indicated as icons in brackets < >.

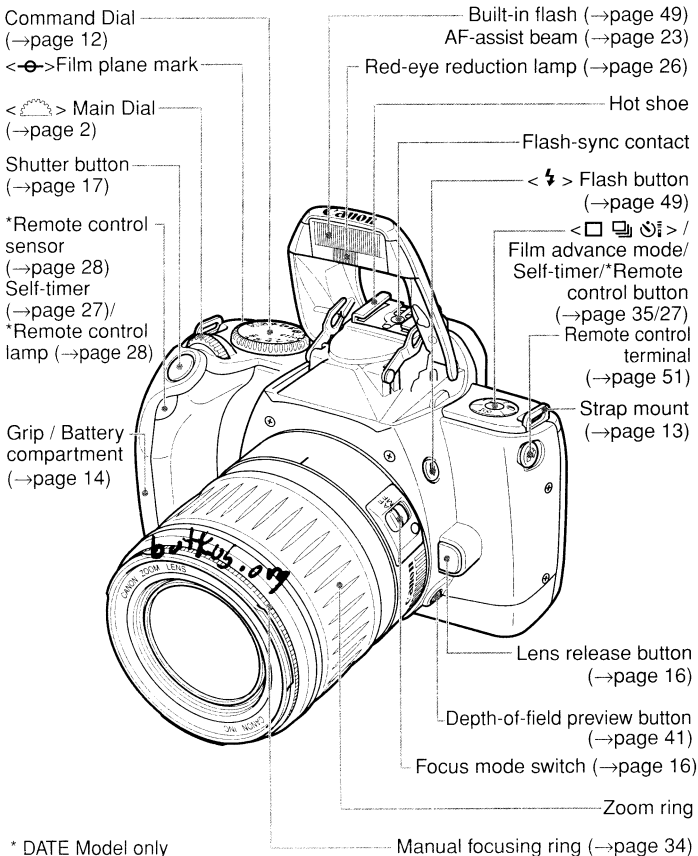

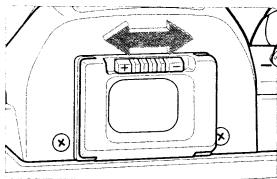
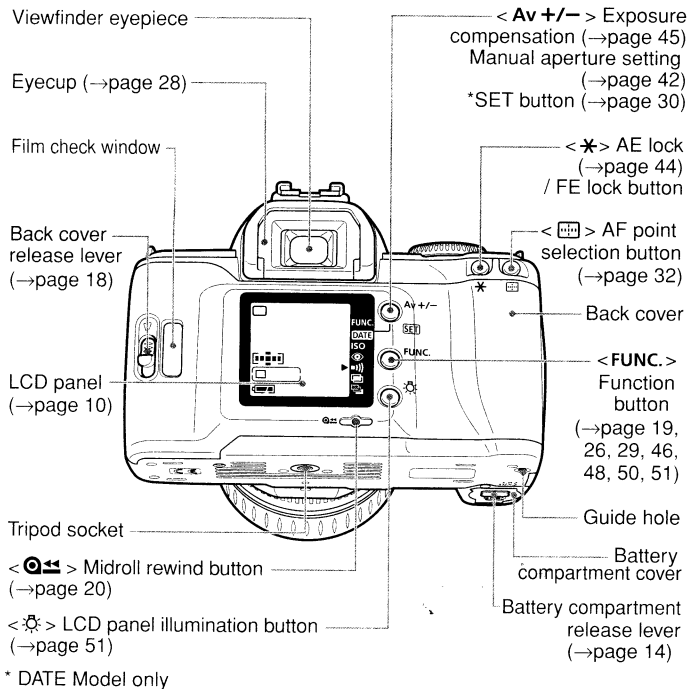

Take off the eyecup, then slide the dioptic adjustment lever left or right until the AF point in the viewfinder looks sharp. The dioptic adjustment range is -2.5 dpt to $+0.5$ dpt.

Nomenclature

LCD Panel

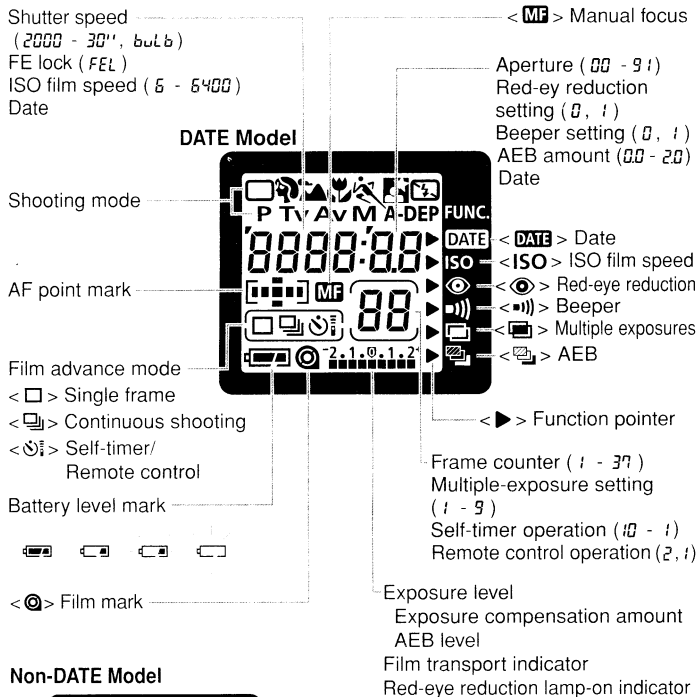

Non-DATE Model

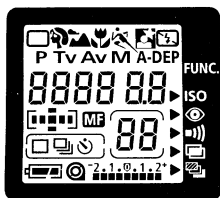

- The LCD panel is shown with all the information displayed. The actual display will look different.

Viewfinder Information

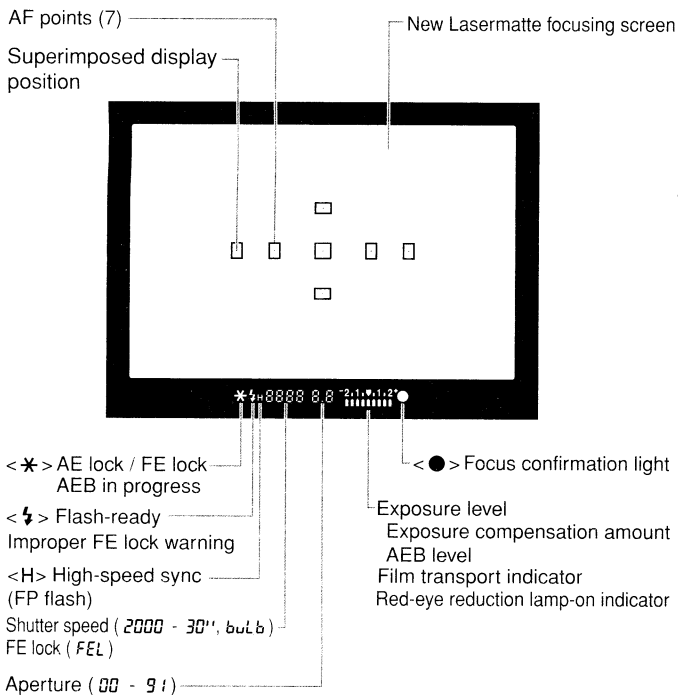

- The LCD panel is shown with all the information displayed. The actual display will look different.

Command Dial

The dial is divided into three zones.

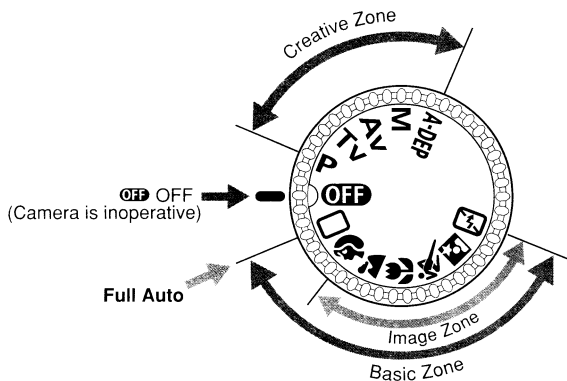

① Basic Zone

Fully automatic mode where the camera takes care of everything.

 : **Full Auto** (→page 22)

Basically, all you do is point and shoot.

Image Zone (→page 24)

Fully automatic modes for a particular subject.

 : Portrait

 : Landscape

 : Close-up

 : Sports

 : Night Portrait

 : Flash off

② Creative Zone

Semi-automatic and manual modes enable you to take control of the camera to obtain the desired result.

P : Program AE (→page 36)

Tv : Shutter-priority AE
(→page 38)

Av : Aperture-priority AE
(→page 40)

M : Manual exposure
(→page 42)

A-DEP : Automatic Depth-of-field AE
(→page 43)

③ OFF : OFF

Before You Start

1

Installing the Batteries and Checking the Battery Level	14
Mounting and Detaching a Lens	16
How the Shutter Button Works	17
📷 Loading and Unloading Film.....	18
🔄 Midroll Rewind	20
Holding the Camera	20

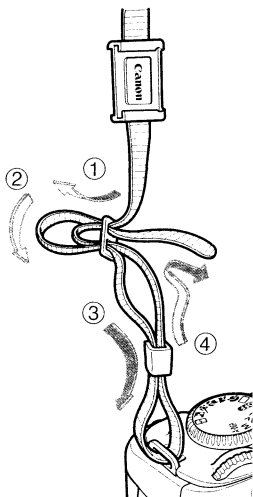

Attaching the Strap

Pass the end of the strap through the camera's strap mount from the bottom. Then pass it through the strap's buckle as shown in the illustration. Pull the strap to make sure it does not slip out of the buckle.

- The eyepiece cover is also attached to the strap.

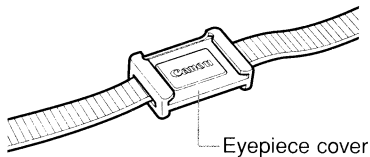

Installing the Batteries and Checking the Battery Level

Installing the Batteries

The camera uses two CR2 lithium batteries.

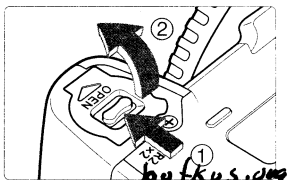

1 Open the battery compartment cover.

- Slide the cover release lever as shown by the arrow and open the battery compartment cover.

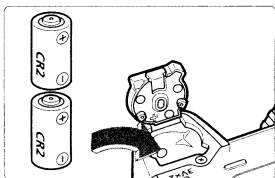

2 Install the batteries.

- Make sure the battery contacts (+ and -) are properly oriented as shown.
- Do not mix old and new batteries.

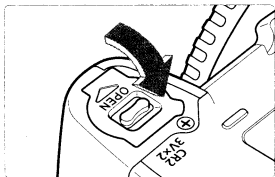

3 Close the battery compartment cover.

- Press the cover until it snaps shut.
- The date and time must be set. See page 30. (DATE Model only)



For places where CR2 batteries may not be easily available, take spare batteries with you. Also carry spare batteries for extended shooting sessions.

Checking the Battery Level

Check the battery level after replacing the batteries and before using the camera.

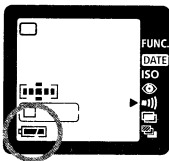
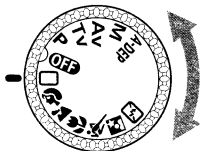

Turn the Command Dial to a shooting mode.

- The camera will then turn on and the LCD panel will display one of the following battery level icons:
 - : Battery level OK.
 - : The battery level is low. Keep spare batteries handy.
 - : The batteries will soon be completely exhausted.
 - : Replace the batteries. (→page 5)

Battery Life

(With 24-ex. rolls)

Temperature	0% Flash Use	50% Flash Use	100% Flash Use
At 20°C	67 rolls	30 rolls	22 rolls
At -10°C	44 rolls	20 rolls	15 rolls

- The battery life shown in the table is based on the Canon's testing conditions with new batteries.



- If nothing is displayed on the LCD panel, the batteries may have been installed incorrectly. Take out the batteries and install correctly. (→page 14)
- Pressing the shutter button halfway for a prolonged period or operating only the autofocus without taking a picture will still consume battery power. It will reduce the number of rolls that can be taken with the batteries.



When not using the camera, set the Command Dial to < **OFF** >.

Mounting and Detaching a Lens

Mounting a Lens

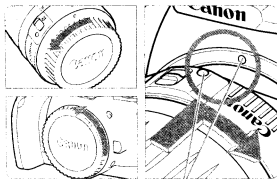

Red dots

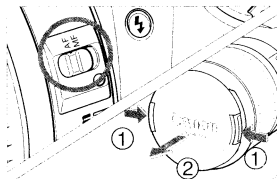

- 1 Remove the caps.**
 - Remove the rear lens cap and the camera body cap.
- 2 Mount the lens.**
 - Align the red dots on the lens and camera and turn the lens as shown by the arrow until it snaps in place.
- 3 On the lens, set the focus mode switch to <AF>.**
 - If the focus mode switch is set to <MF> (or <M> on older lenses), autofocus will not operate and <MF> will be displayed on the LCD panel.
- 4 Remove the front lens cap.**

Detaching the Lens

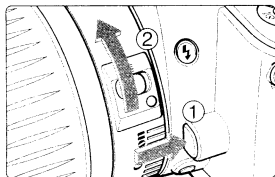

While pressing the lens release button, turn the lens as shown by the arrow.

- When the red dot on the lens is at the top, remove the lens.



- Keep the removed caps where you will not lose them.
- “**AF**” stands for Autofocus.
- “**MF**” (or “**M**”) stands for Manual Focus.

How the Shutter Button Works

The EOS camera's shutter button can be depressed halfway or all the way. There is a click stop at the halfway point.

Pressing the Shutter Button Halfway or Fully

The shutter button works as described below.

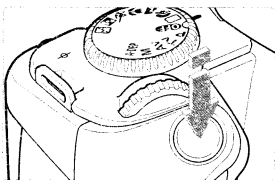

When it is pressed halfway:

- Autofocusing (AF) is activated. When the subject is in focus, the AF point which achieved focus will flash, the beeper will sound, and the focus confirmation light will light up.
- Also, the shutter speed and aperture are set and displayed on the LCD panel and in the viewfinder.

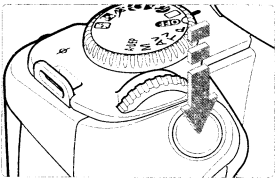

When it is pressed fully:

- The shutter is released to take the picture and the film advances by one frame.

 If an Extender is used and the maximum aperture of the lens becomes smaller than $f/5.6$ (the lowest f /number), autofocusing will not operate.

 Camera movement during the moment of exposure is called camera shake. Camera shake can cause blurred pictures. To prevent blurred pictures due to camera shake:

- Hold the camera steady (→page 20).
- Use your finger tip to touch the shutter button, grasp the camera with your entire right hand, then press the shutter button gently.

Ⓞ Loading and Unloading Film

Loading Film

After you load the film, the camera first winds the entire roll onto the camera's take-up spool. With DX-coded film, the camera automatically sets the film's ISO speed. Then each time a picture is taken, one frame of film is rewound back into the film cartridge. The frame counter shows always number of shots remaining.

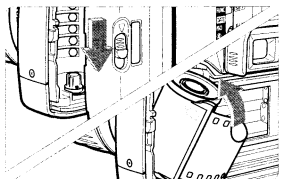

1 Turn the Command Dial to any setting except **<OFF>**.

2 Open the back cover.

- Slide the back cover release lever as shown by the arrow.

3 Insert the film cartridge at an angle as shown in the illustration.

4 Align the edge of the film with the orange **<▲>** index mark.

- Hold down the film cartridge while pulling out the film leader.
- If the edge of the film leader goes beyond the orange mark, rewind some of the film back into the cartridge.

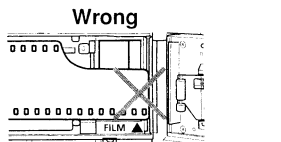
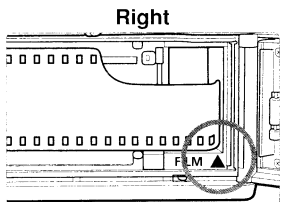

5 Close the back cover.

- Check that the edge of the film is aligned with the **<▲>** mark, then close the back cover until it snaps shut.
- ▶ After you close the back cover, the film will start winding on the take-up spool and the frame counter will count up. The camera will then make a shutter-release sound and the **<Ⓞ>** icon and total frame count will be displayed.
- ▶ During the film's prewind, the ISO speed is displayed on the LCD panel.

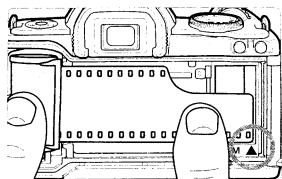

- The shutter curtains have been manufactured with very high precision. Never touch them with your fingers. When loading film, do not touch or damage the curtains with your fingers or film.
- In hot and humid environments, do not remove the film packaging until you are ready to load the film.



- If the film is not loaded properly, the icon will blink on the LCD panel and the shutter will not work. Reload the film cartridge properly. (→page 18)
- If you want to set a film speed different from the DX-coded film speed or if the film cartridge is not DX-coded, see "Setting the ISO Film Speed" on page 50.
- Infrared film cannot be used with this camera.

Checking the Film Speed

The camera reads the film cartridge's DX code and sets the film speed automatically within ISO 25 - 5000.

- Set the Command Dial to a Creative Zone mode.

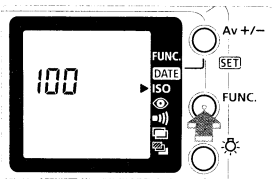

Press the <FUNC.> button and move the <▶> arrow to <ISO> on the LCD panel.

- ▶ The film speed will appear on the LCD panel.

Unloading Film

After the film's last frame is exposed, the camera rewinds the film automatically.

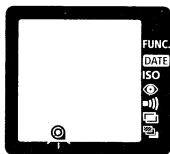

After the film is rewound, there will be a shutter-release sound. Check that the icon is blinking on the LCD panel, then open the back cover and take out the film cartridge.

Ⓢ Loading and Unloading Film

Ⓢ Midroll Rewind

To rewind the film in midroll, follow the procedure below.

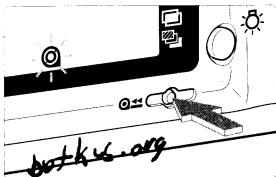

1 Press the < Ⓢ > button.

▶ Film rewind will begin.

2 Take out the film cartridge.

• Make sure the < Ⓢ > icon is blinking on the LCD panel before taking out the film cartridge.

Ⓢ If you take out the film cartridge in midroll without rewinding the film and then load a new roll of film and press the shutter button completely, the new film will only rewind into the cartridge. Before loading a new roll of film in this case, close the camera back and press the shutter button.

Holding the Camera

To avoid taking a blurred shot, hold the camera properly as described below.



Horizontal shooting



Vertical shooting



- Wrap your right hand around the camera grip and grasp firmly. Set your elbow lightly against your body.
- Use your left hand to hold the lens from underneath.
- Press the camera against your forehead and look through the viewfinder.
- Keep one foot slightly ahead of the other for better stability.

Fully Automatic Shooting

2

<input type="checkbox"/> Full Auto Mode	22
AF-Assist beam with the Built-in Flash	23
Programmed Image Control modes	24
👤 Portrait / 🏞 Landscape / 🌸 Close-up	
🏃 Sports / 🌃 Night Portrait / 🚫 Flash off	
👁 Using Red-eye Reduction	26
🕒 Using the Self-timer	27
📶 Wireless Remote Control (DATE Model only) ...	28
Using the Eyepiece Cover	28
DATE Imprinting the Date or Time (DATE Model only) ..	29

Basic Zone modes set all the camera settings automatically. All you do is point and shoot.

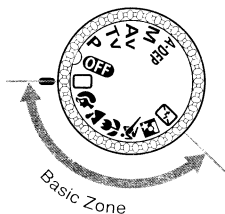

Turn the Command Dial to , 👤,

<🏞 >, <🌸 >, <🏃 >, <🌃 >, <🚫 >, .

- The picture-taking procedure is the same as with the “<input type="checkbox"/> Full Auto mode” on page 22.

Full Auto Mode

All you do is point the camera and press the shutter button. Everything is automatic so it is easy to photograph any subject. With seven AF points to focus the subject, anyone can just point and shoot.

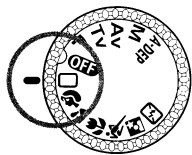

1 Turn the Command Dial to .

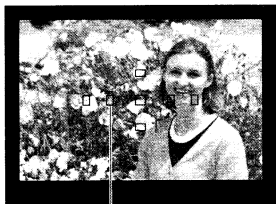

— AF point

2 Aim any of the AF points on the subject.

- The main subject, as determined by the camera, will be focused by one of the AF points.
- To focus a subject not covered by any of the AF points, see “Focusing Off-Center Subjects” on page 33.

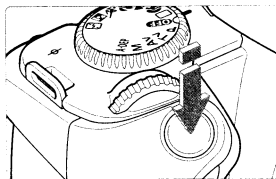

3 Press the shutter button halfway to focus.

- ▶ When necessary, the built-in flash will pop up automatically.
- ▶ When focus is achieved, the AF point will flash, the beeper will sound, and the focus confirmation light will light up.

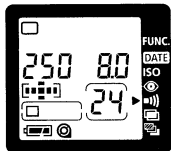

4 Check the exposure setting.



- ▶ The shutter speed and aperture will be set automatically and displayed in the viewfinder and on the LCD panel.

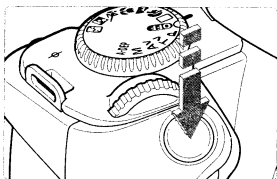







5 Take the picture.





- Compose the shot and press the shutter button fully.

 If the built-in flash's automatic pop-up action is obstructed accidentally, the  icon will blink on the LCD panel as a warning. If this happens, press the shutter button halfway to return the camera to normal operation.

- 
- When focus is achieved, the autofocus and auto exposure setting will also be locked.
 - If the focus confirmation light  blinks, the picture cannot be taken. (→page 34)
 - Out of the seven AF points, the one covering the closest subject is selected automatically to achieve focus.
 - If multiple AF points flash in red, it means that all of them have achieved focus at the respective points.
 - In the Basic Zone modes (except ,  and ), the built-in flash will pop up and fire automatically in low-light or backlit conditions. To retract the flash, push it back down. For more information on the flash, see “Using the Built-in Flash” on page 49.
 - In the Basic Zone modes, the film advance mode (single frame or continuous) will be set automatically depending on the shooting mode. For more information, see the “Feature Availability Table” on page 54.

AF-Assist beam with the Built-in Flash

Under low-light conditions, the built-in flash fires a brief burst of flashes when you press the shutter button halfway. This is to illuminate the subject to enable easier autofocusing.

- 
- The AF-assist beam does not function in the ,  and  modes.
 - The built-in flash's AF-assist beam is effective up to about 4 meters/13.2 feet.
 - In the Creative Zone modes when the built-in flash is popped up with the  button, the AF-assist beam may be emitted.

Programmed Image Control Modes

Select a shooting mode to suit the target subject, and the camera will be set to obtain the best results.

Portrait



This mode blurs the background to make the human subject stand out.

- Holding down the shutter button executes continuous shooting.
- To improve the background blur, use a telephoto lens and fill the frame with the subject or have the subject stand farther away from the background.

Landscape



This is for wide scenic views, night scenes, etc.

- Using a wide-angle lens will further enhance the depth and breadth of the picture.

Close-up



Use this mode to take close-up shots of flowers, insects, etc.

- As much as possible, focus the subject at the lens' closest focusing distance.
- To obtain a larger magnification, use the telephoto end of a zoom lens.
- For better close-ups, an EOS-dedicated macro lens and Macro Ring Lite (both optional) are recommended.

Sports



This is for sports and fast-moving subjects when you want to freeze the action on film.

- The camera will first track the subject with the center AF point. Focus tracking will then continue with any of the seven AF points covering the subject. When focus is achieved, the beeper will sound softly.
- While you hold down the shutter button, focusing will continue for continuous shooting.
- Using a telephoto lens and ISO 400 or higher speed film is recommended.

Night Portrait



This mode is for taking pictures of people at twilight or at night. The flash illuminates the subject while a slow sync speed obtains a natural-looking exposure of the background.





- If you want to photograph only a night scene (without people), use the  mode instead.
- Tell the subject to keep still even after the flash fires.
- If you also use the self-timer (→page 27), the self-timer lamp will flash to indicate that the picture was taken.

Flash off



You can disable the flash when you do not want it to fire.

- The built-in flash or any external Speedlite will not fire.

 In the  mode, use a tripod to prevent camera shake. In the  or  mode, use a tripod if the shutter speed display blinks.

👁 Using Red-eye Reduction (with the built-in flash)

When flash is used in a low-light environment, the subject's eyes may come out red in the photograph. "Red eye" happens when the light from the flash reflects off the retina of the eyes. The camera's red-eye reduction feature turns on the red-eye reduction lamp to shine a gentle light into the subject's eyes to narrow the pupil diameter or iris. A smaller pupil reduces the chances of red eye from occurring. Red-eye reduction can be set in any shooting mode except < 🏔 >, < 🏹 > and < 📷 >.

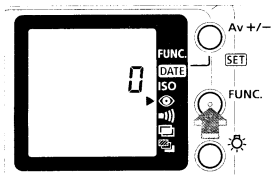

1 Move the < ▶ > arrow to the < 👁 > icon on the LCD panel.

- Look at the LCD panel and press the < FUNC. > button to move the arrow. (🔁6)

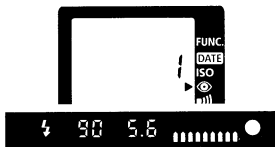

2 Turn the < 🌀 > dial to set " ! " on the LCD panel.

- Press the shutter button halfway to return to normal camera operation.
- When red-eye reduction is enabled, the red-eye reduction lamp-on indicator will be displayed in the viewfinder and on the LCD panel when you press the shutter button halfway.
- To cancel red-eye reduction, set " 📷 " on the LCD panel.

Red-eye reduction lamp-on indicator



- Red-eye reduction will not work unless the subject looks at the red-eye reduction lamp. Tell the subject to look at the lamp.
- For maximum effectiveness, take the picture after the red-eye reduction lamp turns off (after 1.5 sec.).
- You can take a picture even while the red-eye reduction lamp is lit.
- The effectiveness of red-eye reduction varies depending on the subject.
- To further increase the effectiveness of red-eye reduction, go to a brighter environment or move closer to the subject.

Using the Self-timer

The self-timer is useful when you want to be in the picture. It can be used in Basic Zone and Creative Zone modes. You should use a tripod.

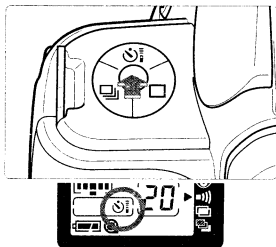

1 Show the <Self-timer icon> on the LCD panel.

- Press the <Self-timer icon> button to display the <Self-timer icon>.
- To cancel the self-timer, press the <Self-timer icon> button again or turn the Command Dial to <OFF>.

2 Take the picture.

- The picture-taking procedure is the same as with the <Full Auto mode> on page 22.
- Look through the viewfinder and press the shutter button fully to start the self-timer.
- ▶ When you press the shutter button fully, the beeper will sound and the picture will be taken 10 sec. later. During the first 8 sec., the beeper beeps slowly and the self-timer lamp blinks slowly. During the final 2 sec., the beeper beeps quickly and the self-timer lamp blinks quickly.
- ▶ Also, the self-timer display on the LCD panel counts down in seconds.

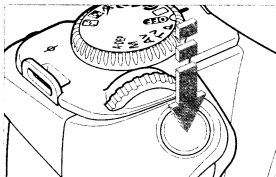

Do not stand in front of the camera when you start the self-timer. Doing so will throw off the focus.

- To cancel the self-timer after it starts, press the <Self-timer icon> button again.
- When using the self-timer to take a picture of only yourself, first lock the focus (→page 33) on an object at the same distance where you will be in the picture.

Wireless Remote Control (DATE Model only)

With Remote Controller RC-1 (optional), wireless operation is possible up to 5 meters away from the front of the camera.

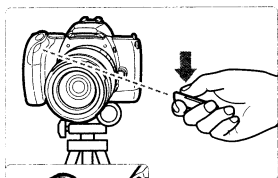

1 Show the <☺i> icon on the LCD panel.

- Press the <☐☑☺i> button to display the <☺i> icon.

2 Take the picture.

- Point the controller toward the camera's remote control sensor and press the transmit button.
- Display indications

2-sec. delay: The indicator will be the same as during the last 2 sec. of the self-timer.

No delay: When the picture is taken, the self-timer/wireless remote control lamp will flash.



Certain types of fluorescent lights might cause the remote control operation to work improperly. Place the camera away from any fluorescent lights as far as possible.



If you set the film advance mode lever to <☺i> and do nothing for four minutes, the wireless remote control mode will be canceled automatically to save battery power.

Using the Eyepiece Cover

When you use the self-timer or wireless remote control and your eye does not cover the eyepiece, stray light entering the eyepiece may affect the exposure setting. To prevent this, attach the eyepiece cover to the eyepiece.

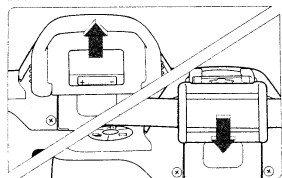

1 Remove the eyecup from the eyepiece.

2 Slip on the Eyepiece cover (→page 13) over the eyepiece.

DATE Imprinting the Date or Time (DATE Model only)



The date or time is imprinted on the lower right corner of the photograph.

The camera has a date feature with an automatic calendar to 2099. It can imprint the date or time on the photograph as shown in the left photo. The imprinting can also be disabled so nothing is imprinted.

The date or time can be imprinted in any shooting mode.

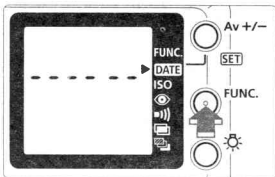

1 Move the <▶> arrow to <DATE>. (06)

- Look at the LCD panel and press the <FUNC.> button.
- If the date and time has not been set, "....." will blink on the LCD panel. See page 30 to set the date and time.

2 Select the date format.

- Turn the <☀> dial.
- ▶ The date format will change in the following loop:

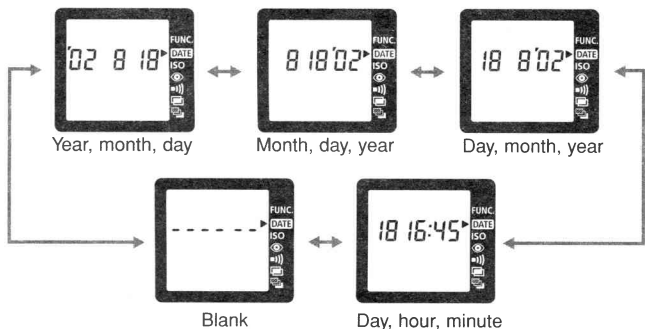

Setting the Date and Time

- 1 **Move the <▶> arrow to <DATE>.**
 - Look at the LCD panel and press the <FUNC.> button.
 - ▶ If the date and time has not been set, “.....” will blink on the LCD panel.



- 2 **Select the digit to be set.**
 - Press the <SET> button.
 - The digit selection will change in the following sequence: year, month, day, hour, minute, “:”.



- 3 **Set the correct number.**
 - Turn the <☀> dial.
 - Repeat steps 2 and 3 until all the date and time digits are set correctly.









- 4 **Finalize the date and time setting.**
 - Keep pressing the <SET> button until no digits are blinking.
 - If you press the <SET> button while “:” is blinking, 0 sec. will be set.

📷 If a picture is taken while the date and time are blinking, the date and time will not be imprinted on that picture.

📄 The date and time setting can be retained for about 10 min. after the camera's batteries are removed.

User-Controlled Shooting

3

 Selecting an AF point.....	32
Focusing Off-Center Subjects	33
When Autofocus Fails.....	34
 Selecting the Film Advance Mode.....	35
Metering Modes.....	35
P : Program AE.....	36
Tv : Shutter-Priority AE.....	38
Av : Aperture-Priority AE	40
Depth-of-field Preview	41
M : Manual Exposure	42
A-DEP : Automatic Depth-of-Field AE	43
* AE Lock.....	44
Av +/- : Exposure Compensation.....	45
 Auto Exposure Bracketing (AEB)	46
Bulb Exposures	47
 Multiple Exposures.....	48
Using the Built-in Flash	49
ISO : Setting the ISO Film Speed.....	50
 Silencing the Beeper.....	51
 LCD Panel Illumination	51
Using the Remote Switch.....	51

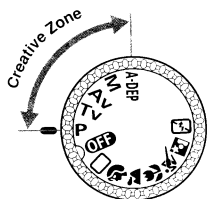

The Creative Zone modes enables you to set any shutter speed and aperture to obtain the exposure or effect you want.

- You can set the AF point, film advance mode, AE lock, exposure compensation, AEB, multiple exposures, and depth-of-field preview.

Selecting an AF point

The AF point is used for focusing. The AF point can be selected automatically by the camera or manually by you. In the Basic Zone modes and <A-DEP> mode, the AF point selection is automatic only. In the <P>, <Tv>, <Av>, and <M> modes, the AF point can be selected either automatically or manually.

Automatic AF point Selection

The camera selects the AF point automatically according to situation.

Manual AF point Selection

You can select any of the seven AF points manually. This is best when you want to be sure to focus on a particular subject, or to use the time of the AF function to help you compose a particular shot quickly.

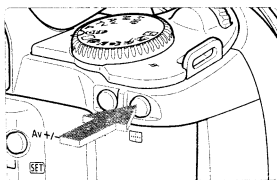

- 1 Press the <> button. (⊕6)
▶ The current AF point will light.

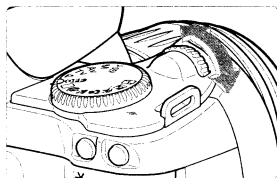
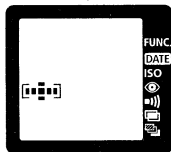

- 2 Select the desired AF point.
 - While looking at the AF points on the LCD panel or in the viewfinder, turn the <> dial to select the desired AF point. The selected AF point will flash in the viewfinder. The AF point selection will change in the looping sequence below.
 - After selecting the AF point, press the shutter button halfway. The camera will then be ready to take pictures.



Focusing Off-Center Subjects

If you want to focus an off-center subject not covered by any of the AF points, use focus lock as described below.

- 1 Select the desired AF point.**
(→page 32)



- 2 Focus the subject.**
 - Aim the AF point on the subject, then press the shutter button halfway.

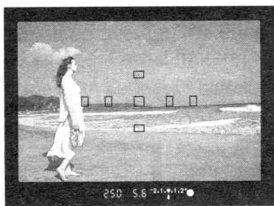

- 3 Keep pressing the shutter button halfway and recompose the picture as desired.**

- 4 Take the picture.**



Focus lock also works in the Basic Zone modes (except <  >). Just start from step 2 above.

When Autofocus Fails

The camera has a high-precision AF system which can focus almost all subjects. However, it can fail to achieve focus (the focus confirmation light <●> blinks) the subjects listed below.

Difficult Subjects for Autofocusing

- Low-contrast subjects. Example: Blue sky, flat surface with a solid color.
- Subjects in very low light.
- Extremely backlit or reflective subjects. Example: Automobile with a strong reflection.
- Overlapping near and far objects. Example: Animal behind bars in a cage.

In such cases, use one of the following methods to focus:

- (1) Focus lock an object at the same distance as the subject and recompose.
- (2) Set the lens focus mode switch to <MF> or <M> and focus manually as explained below.



If focus cannot be achieved even with the EOS-dedicated Speedlite's AF-assist light, select the center AF point.

MF Manual Focusing

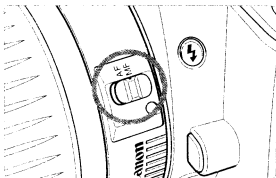

1 **Set the lens focus mode switch to <MF> (or <M> on older lenses).**

- ▶ The <MF> icon will be displayed on the LCD panel.

2 **Focus the subject.**

- Turn the lens manual focusing ring until the subject is in focus in the viewfinder.









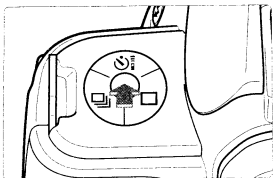

If you hold down the shutter button halfway while focusing manually, the active AF point will flash and the focus confirmation light <●> will light when focus is achieved.

Selecting the Film Advance Mode

Two film advance modes are provided: single-frame and continuous shooting.



Press the    > button.

- Show the  (single) or  (continuous) icon on the LCD panel.
- ▶ Each time you press the    > button, the icons will appear in the following looping sequence:

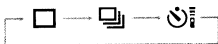

- The continuous shooting speed is approx. 2.5 frames per sec.

Metering Modes

The camera has three metering modes: Evaluative, partial, and center-weighted average metering. Evaluative metering is the standard metering mode. Partial metering is set automatically when AE lock is used (→page 44), and centerweighted average metering is set automatically in the <M> mode (→page 42).



Evaluative metering

This is an all-around metering mode suited even for backlit subjects. The viewfinder field is divided into 35 metering zones to which the three AF points are linked for evaluative metering. The camera determines the main subject's size, position, brightness, background, front and back lighting, etc., so that it can select the proper exposure for the subject at all times.



Partial metering

This is particularly effective when the background is much brighter than the subject due to backlighting, etc. This method uses a center area of approximately 9.5% of the screen.

- The area covered by partial metering is shown on the left.



Centerweighted average metering

The metering is weighted at the center and then averaged for the entire scene.

-  In the One-Shot AF and AI Focus AF (except AI Servo AF) modes (→page 55), when you press the shutter button halfway and focus is achieved, the exposure is locked automatically at the same time.

P:Program AE



Like the <□> (Full Auto) mode, this is a general-purpose mode to make picture-taking easy. It sets the shutter speed and aperture automatically to suit the subject's brightness.

* "P" stands for Program.

* "AE" stands for auto exposure.

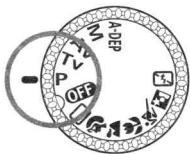

1 Turn the Command Dial to <P>.

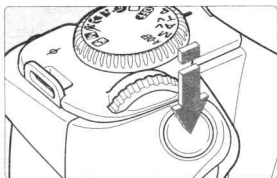

2 Press the shutter button halfway to focus.

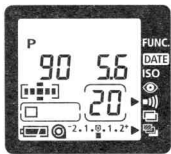

3 Check the display.

- ▶ The shutter speed and aperture are set automatically and displayed in the viewfinder and on the LCD panel.
- If the shutter speed and aperture do not blink, a correct exposure will be obtained.
- If the shutter speed and aperture blink, see "Exposure Warning List" on page 53.



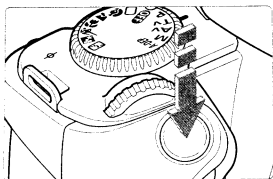

4 Take the picture.

- Compose the shot and press the shutter button fully.



The Difference Between <P> and <□>

- The <P> and <□> modes set the same shutter speed and aperture settings automatically for picture-taking.
- The following features can be used with <P>, but not with <□>:
 - Manual AF point selection
 - Film advance mode selection
 - Program shift
 - AE lock with the <✳> button
 - Exposure compensation
 - AEB
 - Depth-of-field preview
 - Multiple exposures
 - Built-in flash ON/OFF

About Program Shift

- In the Program AE mode, you can freely change the shutter speed and aperture combination (program) set by the camera while retaining the same exposure. This is called program shift.
- To shift the program, press the shutter button halfway and turn the <☀> dial until the desired shutter speed or aperture is displayed.
- After the picture is taken with the shifted program, the shifted program is canceled automatically and the original program is restored.
- Program shift cannot be set when the built-in flash is used.

Tv:Shutter-Priority AE

In this mode, you set the shutter speed and the camera sets the aperture automatically to suit the brightness of the scene.

A fast shutter speed can freeze the motion of a fast-moving subject. Or, a slow shutter speed can blur the subject to give the impression of motion.

* "Tv" stands for Time value which is the shutter speed.

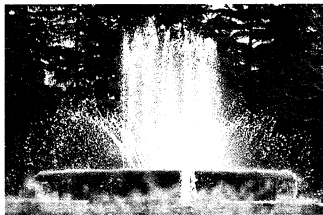

Taken with a fast shutter speed.

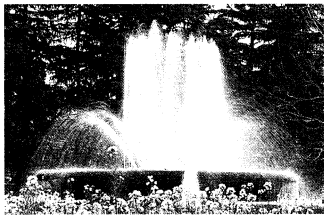

Taken with a slow shutter speed.

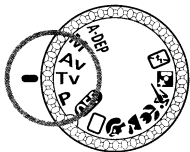

1 Turn the Command Dial to <Tv>.

2 Select the desired shutter speed.

- Look at the LCD panel and turn the <DIAL> dial to set the desired shutter speed.

3 Press the shutter button halfway to focus the subject.

- ▶ The aperture is set automatically.

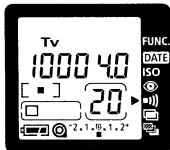

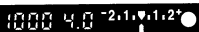



4 Check the viewfinder display and take the picture.

- If the aperture display is not blinking, a correct exposure will be obtained.



- If the maximum aperture (the lowest f/number) blinks, it indicates underexposure. In such a case, turn the  dial to set a slower shutter speed until the aperture display stops blinking.



- If the minimum aperture (the highest f/number) blinks, it indicates overexposure. In such a case, turn the  dial to set a faster shutter speed until the aperture display stops blinking.

Shutter Speed Display

- The shutter speed can be set and displayed in full and half stops. Shutter speeds from "2" to "2000" indicate the denominator of the fractional shutter speed. For example, "125" is 1/125 second. For slower shutter speeds, the numeral is appended with the seconds mark (""). For example, "0.7" is 0.7 second and "15" is 15 seconds.

2000	1500	1000	750	500	350	250	180	125				
90	60	45	30	20	15	10	8	6	4	3	2	0.7
"	"	"	"	"	"	"	"	"	"	"	"	"

- When photographing a TV screen, use 1/15 sec. shutter speed for best results.

Av:Aperture-Priority AE

In this mode, you set the aperture and the camera sets the shutter speed automatically to suit the brightness of the subject.

A large aperture (lower f/number) will blur the background and make the subject stand out. The larger the aperture, the more blurred the background will look.

Or, a smaller aperture (higher f/number) will increase the depth of field to make both the foreground and background look sharp. The smaller the aperture, the sharper the background will look.

* "Av" stands for aperture value.

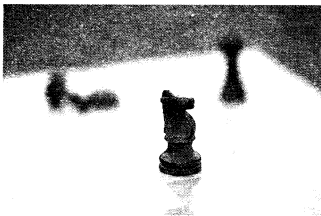

Taken with a large aperture.

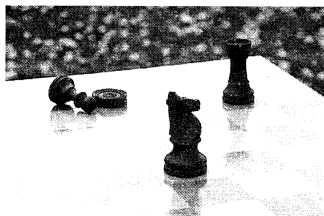

Taken with a small aperture.

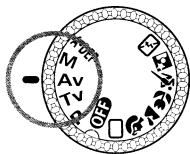

1 Turn the Command Dial to <Av>.

2 Select the desired aperture.

- Look at the LCD panel and turn the <DIAL> dial to set the desired aperture.

3 Press the shutter button halfway to focus the subject.

- ▶ The shutter speed is set automatically.

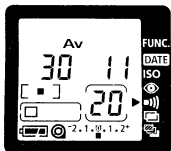



4 Check the viewfinder display and take the picture.

- If the shutter speed display does not blink, a correct exposure will be obtained.
- If the slowest shutter speed blinks, it indicates underexposure. In such a case, turn the < > dial to set a larger aperture (smaller f/number) until the shutter speed display stops blinking.
- If the fastest shutter speed blinks, it indicates overexposure. In such a case, turn the < > dial to set a smaller aperture (larger f/number) until the shutter speed display stops blinking.



Aperture Display

The aperture can be set and displayed in full and half stops as shown below. The larger the number, the smaller the aperture opening will be. The displayable range of apertures depends on the lens mounted on the camera.

1.0	1.2	1.4	1.8	2.0	2.5	2.8	3.5	4.0	4.5	5.6
6.7	8.0	9.5	11	13	16	19	22	27	32	38
45	54	64	76	91						

Depth-of-field Preview

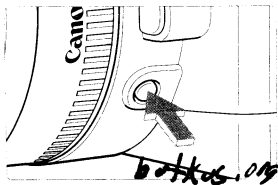

To check the depth of field, press the depth-of-field preview button. The camera will stop down the aperture and you can check the in-focus range in the viewfinder.







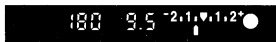
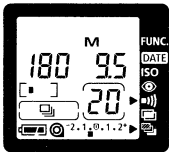
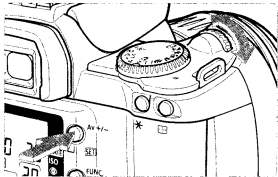
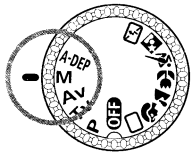

- This feature works in Creative Zone modes.
- When you press the depth-of-field preview button, AE lock also takes effect.
- In the < **A-DEP** > mode, press the shutter button halfway to focus, then keep pressing the shutter button halfway and press the depth-of-field preview button.

M:Manual Exposure

In this mode, you set both the shutter speed and the aperture for total exposure control. The exposure level of the shutter speed and aperture you set is indicated on the exposure level scale. You can thereby check how suitable the exposure will be. In the <M> mode, the centerweighted average metering will be set automatically. * "M" stands for Manual.



- 1 Turn the Command Dial to <M>.
- 2 Set the shutter speed and aperture.
 - To set the shutter speed, turn the <  > dial.
 - To set the aperture, hold down the < Av +/- > button and turn the <  > dial.
- 3 Press the shutter button halfway to focus the subject.
 - ▶ The exposure level will be displayed in the viewfinder and on the LCD panel.
 - The exposure level indicator <  > indicates how close the exposure level is to the correct exposure.
- 4 Set the desired exposure.
 - Look at the exposure level indicator and set the shutter speed and aperture as desired.
 - If the exposure level indicator <  > blinks at < 2+ > or < -2 >, it indicates that the exposure is respectively overexposed or underexposed by 2 stops or more.

- Correct exposure -2.1, , 1, 2+ : This is the standard level for a correct exposure.
- Over exposure -2.1, , 1, 2+ : To achieve the correct exposure, set a faster shutter speed or a smaller aperture.
- Under exposure -2.1, , 1, 2+ : To achieve the correct exposure, set a slower shutter speed or a larger aperture.

A-DEP :Automatic Depth-of-Field AE

This mode is for obtaining a wide depth of field automatically between a near subject and far subject. It is effective for group photos and landscapes. The camera uses the 7 AF points to detect the nearest and farthest subjects to be in focus.

* "A-DEP" stands for Auto-depth of field.

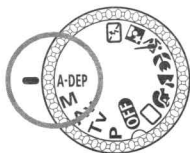

1 Turn the Command Dial to <A-DEP>.

2 Focus the subject.

- Move the AF point over the subject and press the shutter button halfway.
- All the subjects covered by the AF points which flashed in red will be in focus.
- If you press the depth-of-field preview button while the exposure reading is displayed in the viewfinder, you can see the depth of field. (→page 41)

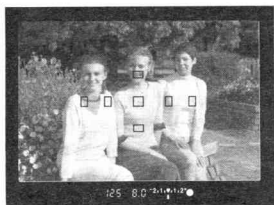

3 Check the viewfinder display and take the picture.

- In the example above, the focus will be sharp between the front person on the left and the rear person on the right.



The <A-DEP> mode cannot be used if the lens' focus mode switch is set to <MF> (or <M> on older lenses).



- If the aperture blinks, it indicates that the exposure level is correct but the desired depth of field cannot be achieved. Either use a wide-angle lens or move further away from the subjects.
- In this shooting mode, you cannot freely change the shutter speed and aperture. If the camera sets a slow shutter speed, hold the camera steady or use a tripod.
- If flash is used, the result will be the same as using flash in the <P> mode.

✳ AE Lock

With the same AF point, you can obtain and lock the auto exposure setting on one part of the picture and then recompose to focus a different part of the picture. AE lock enables you to maintain the same exposure setting even after recomposing the shot. This is effective for backlit subjects. During AE lock, partial metering (→page 35) is used automatically.



1 Focus the subject.

- Press the shutter button halfway to focus. (⓪4)

Proceed to steps 2 and 3 holding the shutter button halfway down.

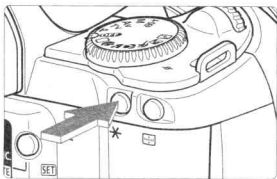

2 Aim the viewfinder center over the part where you want to lock the exposure, then press the <✳> button. (⓪4)

- ▶ The <✳> indicator lights in the viewfinder and the exposure setting locks (AE lock).
- The auto exposure locks every time you press the <✳> button.

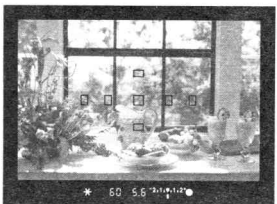

3 Compose the shot and take the picture.

- If you want to maintain the AE lock while taking more pictures, hold down the <✳> button and press the shutter button to take another picture.

Av +/- : Exposure Compensation

Changing the exposure level set by the camera is called exposure compensation. Exposure compensation can be used to make the picture darker or brighter intentionally. Exposure compensation can be set up to +/-2 stops in half-stop increments.

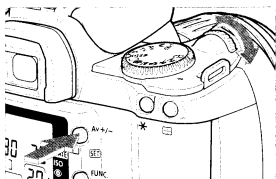

Increased exposure amount

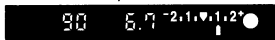

Decreased exposure amount

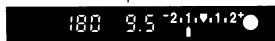

- The exposure compensation amount is canceled automatically when you turn the Command Dial to a Basic Zone mode.
- Assuming that a shutter speed of 1/125 sec. and an aperture of f/5.6 will give a correct exposure, setting the exposure compensation amount to plus or minus 1 stop will change the shutter speed or aperture as follows:

	-1 stop	←	0	→	+1 stop
Shutter Speed	250	←	125	→	60
Aperture	8.0	←	5.6	→	4.0

- 1 Turn the Command Dial to a Creative Zone mode except <M>.
- 2 Press the shutter button halfway and check the exposure display.
- 3 Press and hold down the <Av +/-> button and turn the <[Dial]> dial until the desired exposure compensation amount is set. (ⓘ4)
 - The <+> side of the scale indicates increased exposure, and the <-> side of the scale indicates decreased exposure.
- 4 Take the picture.

Decreased exposure amount -2.1, 0, 1.2+ Increased exposure amount

- The exposure compensation amount set is retained even after the Command Dial is set to <OFF>.
- To cancel the exposure compensation, set the exposure level indicator back to <0>.

Auto Exposure Bracketing (AEB)

With AEB, the camera automatically changes the exposure within the set range (up to ± 2 stops in 1/2-stop increments) for three successive frames.

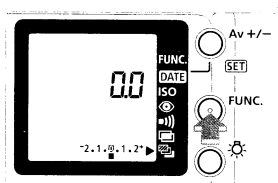

1 Move the \blacktriangle arrow to the $\langle \text{AEB} \rangle$ icon.

- Look at the LCD panel and press the $\langle \text{FUNC.} \rangle$ button. (\odot)

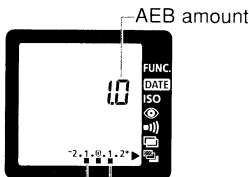

2 Set the desired AEB amount.

- Turn the $\langle \text{AEB} \rangle$ dial.
- ▶ The AEB amount and AEB range $\langle \blacksquare \rangle$ are displayed on the LCD panel.
 - The sample illustration left shows an AEB amount of 1 stop with respect to the correct exposure level.

-2.1.0.1.2+ Correct exposure

-2.1.0.1.2+ Decreased exposure

-2.1.0.1.2+ Increased exposure

3 Take the picture.

- ▶ The respective AEB amount is displayed on the LCD panel and in the viewfinder for each bracketed shot.
- The picture will be taken in the current film advance mode. (\rightarrow page 35)
- After the three AEB shots are taken, the AEB will not be canceled automatically. To cancel AEB, set the AEB amount back to "0.0".

\odot AEB cannot be used with flash or bulb exposures.

- AEB • During AEB shooting, the \blacktriangle arrow mark and $\langle \blacksquare \rangle$ AEB level icon next to the $\langle \text{AEB} \rangle$ icon will blink.
- In the $\langle \text{AEB} \rangle$ film advance mode, the camera will stop shooting automatically after three shots.
- If the self-timer or remote control is used, the three AEB shots will be taken in continuous succession automatically.
- AEB can be combined with exposure compensation.

Bulb Exposures

A bulb exposure starts when you press the shutter button fully and ends when you release the shutter button. Bulb exposures are useful when long exposures are required for night scenes, fireworks, astronomical photography, etc.

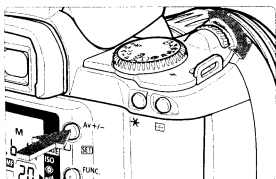
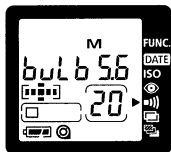
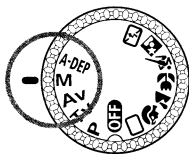

1 Turn the Command Dial to <M>.

2 Set the shutter speed to "bulb".

- Turn the <☀> dial until "bulb" is displayed on the LCD panel.
- "bulb" follows "30''".

3 Press and hold down the <Av +/-> button and turn the <☀> dial to set the desired aperture.

4 Start the bulb exposure.

- Press and hold down the shutter button.
- ▶ During the bulb exposure, "bulb" blinks on the LCD panel.
- The bulb exposure continues as long as you hold down the shutter button.



- Remote Switch RS-60E3 (optional) is recommended for bulb exposures.
- Bulb exposures can also be taken with wireless remote control (optional). Press the transmit button to start the exposure, and press it again to stop the exposure. (DATE Model only)
- With a new set of batteries, the maximum bulb exposure time (at 20°C) will be about 4 hours.

Multiple Exposures

By not advancing the film after taking a picture, up to nine exposures can be shot on a single frame.

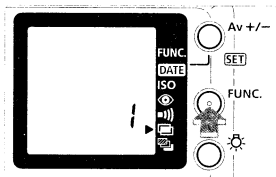

1 Move the <▶> arrow to the <> icon.

- Look at the LCD panel and press the <FUNC.> button. (ⓘ6)
- ▶ The frame counter will show “1”.

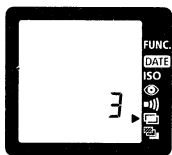

2 Set the desired number of multiple exposures.



- Turn the <> dial.

Three multiple exposures have been set above.

3 Take the picture.

- ▶ After you take all the multiple exposures, the film advances to the next frame automatically and the multiple-exposure setting is canceled.

 If you shoot multiple exposures on the first few or last few frames of a roll, the multiple exposures might not be precisely aligned due to the film curling.

- 
- During multiple-exposure shooting, the <▶> arrow next to the <> icon on the LCD panel will blink.
 - To cancel multiple exposures before shooting, set the number of multiple exposures to 1.
 - To cancel multiple exposures after shooting, follow steps 1 and 2 to set the number of multiple exposures to blank.

Using the Built-in Flash

In a Basic Zone Mode

In a Basic Zone mode (except <  >, <  > and <  >), the built-in flash will pop up and fire automatically in low-light or backlit conditions.

In a Creative Zone Mode

When using a Creative Zone mode, press the <  > button to pop up the built-in flash.

- P** : Use this mode for automatic flash photography. The flash sync speed and flash aperture will be set automatically as with the <  > (Full Auto) mode.
- Tv** : Use this mode if you want to set a flash sync speed slower than 1/90 sec. The camera will set the flash aperture automatically to obtain a correct flash exposure.
- Av** : Use this mode if you want to set the flash aperture. In this mode, you can obtain a balanced exposure between the subject and a dark background (night scene, etc.) with a slow sync speed set automatically by the camera. The flash illuminates the subject while the background is exposed with a long shutter speed.
- M** : This mode enables you to set both the flash sync speed and flash aperture. The subject is properly exposed with the flash and the background is exposed with the flash sync speed and aperture you have set.
- A-DEP** : The result will be the same as using the < **P** > mode.

Flash Sync Speeds and Flash Apertures

Mode	Sync Speed	Flash Aperture
P	The sync speed is set automatically to 1/90 sec.	The flash aperture is set automatically according to the TTL program.
Tv	Any sync speed 1/90 sec. or slower can be set manually.*	The flash aperture is set automatically to match the sync speed you set.
Av	The sync speed is set automatically within a range of 30" to 1/90 sec. to match the flash aperture you set.	You set the flash aperture manually.
M	Any sync speed 1/90 sec. or slower can be set manually.*	

* If the sync speed is set faster than 1/90 sec., it will be reset automatically to 1/90 sec.

Using the Built-in Flash

Flash Distance Range (With EF 28-90mm f/4-5.6)

ISO	28mm		90mm	
	Negative Film	Slide Film	Negative Film	Slide Film
100	m / ft 1 - 4.2 / 3.3 - 13.1	1 - 3.0 / 3.3 - 9.8	1 - 3.0 / 3.3 - 9.8	1 - 2.1 / 3.3 - 6.9
400	m / ft 1 - 8.5 / 3.3 - 27.9	1.2 - 6.0 / 3.9 - 29.5	1 - 6.0 / 3.3 - 19.7	1 - 4.3 / 3.3 - 14.1

- When using the built-in flash, stay at least 1 meter/3.3 feet away from the subject. Otherwise, part of the photo will look dark.
 - When using the built-in flash, detach any hood attached to the lens. A lens hood will partially obstruct the flash coverage.
 - When a super telephoto lens or a fast, large-aperture lens is attached, the built-in flash coverage might be obstructed.
-  • To retract the built-in flash, push it down.
- The built-in flash's flash coverage is 28mm lens angle.
 - If more light is required, use an external, EOS-dedicated Speedlite (optional).

ISO:Setting the ISO Film Speed

If the film is not DX-coded or if you want to set a different film speed, you can set the film speed manually after loading the film into the camera. The settable film speed range is ISO 6 to 6400.

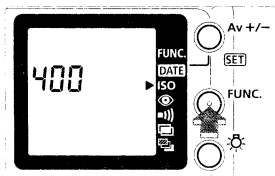

 **Move the <▶> arrow to the <ISO> icon.**

- Look at the LCD panel and press the < FUNC. > button to move the arrow. (⊙6)
- ▶ The current film speed is displayed.

 **Set the desired film speed.**

- Turn the <  > dial to set the film speed.

-  The manually-set film speed will be canceled if the film is taken out and DX-coded film is loaded.

■)) Silencing the Beeper

The beeper can be silenced in all of the shooting modes.

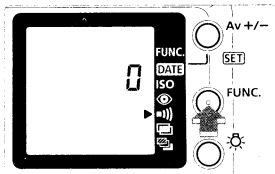

1 Move the <▶> arrow to the <■))> icon.

- Look at the LCD panel and press the < FUNC. > button. (Ⓞ6)

2 Set the setting to “0”.

- Turn the <☀> dial.
- To enable the beeper to sound, set to “1”.

☀ LCD Panel Illumination

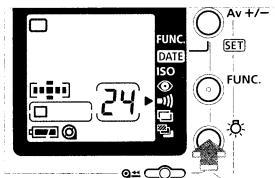

Illuminating the LCD panel.

- Press the <☀> button. (Ⓞ6)
- To turn off the illumination, press the <☀> button again or press the shutter button halfway.
- While the LCD panel is illuminated, pressing any buttons (except the shutter button) or turning any dials will extend the illumination time.

Using the Remote Switch

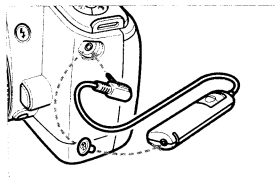

Connect the (optional) Remote Switch RS-60E3's plug to the camera's remote control terminal. Press the release button to take the picture.

Reference

Basic Photography Terms

Exposure

Exposure occurs when the film is exposed to light. Correct exposure is obtained when the film is exposed to a proper amount of light in accordance with the film's sensitivity to light. The correct exposure is adjusted with the camera's shutter speed and lens aperture.

Shutter speed

The shutter speed is the length of time the camera's shutter opens to expose the film to the light coming through the lens. The shutter speed is displayed on the camera's LCD panel and in the viewfinder. It ranges from 1/2000 sec. to 30 sec. and bulb.

Aperture

The aperture setting (f/number) indicates the size of the aperture opening in the lens (focal length/aperture diameter). It is used to adjust the amount of light striking the film. The aperture setting is displayed on the camera's LCD panel and in the viewfinder. It can range anywhere from 1.0 to 91, depending on the lens attached to the camera.

ISO film speed

The ISO film speed indicates the film's sensitivity to light. The higher the film speed, the more sensitive the film is. Therefore, ISO 400 and high-speed films are suited for low-light conditions. The ISO film speed is set in accordance with standards set by the International Standardization Organization (ISO). A film speed from 6 to 6400 can be displayed on the LCD panel.

Depth of field

This is the range where acceptable focus can be achieved in front of and behind the point of optimum focus. The smaller the aperture (the larger the f/number), the deeper the depth of field. And the larger the aperture (the smaller the f/number), the shallower the depth of field.

(→page 40)

Exposure Warning List

Free from hotkus.org

Mode	Blinking Warning	Indication	Countermeasures
P		The subject is too dark.	Use flash.
		The subject is too bright.	Attach a neutral density filter to the lens.
Tv		The picture will be underexposed.	Turn the < > dial to set a slower shutter speed.
		The picture will be overexposed.	Turn the < > dial to set a faster shutter speed.
Av		The picture will be underexposed.	Turn the < > dial to set a larger aperture (smaller f/number).
		The picture will be overexposed.	Turn the < > dial to set a smaller aperture (larger f/number).
A-DEP		The desired depth of field cannot be obtained.	1) Move away from the subject and try again. 2) If a zoom lens is used, use the shortest focal length.
		The subject is too dark.	Use flash. The result will be the same as using the < P > mode.
		The subject is too bright.	Attach a neutral density (ND) filter to the lens.

The sample warnings above apply when the lens used has a maximum aperture of f/4.0 and minimum aperture of f/22. The maximum and minimum aperture warning displays will differ depending on the lens attached to the camera.

Reference

Feature Availability Table

Command Dial Mode									P	Tv	Av	M	A-DEP	
AF	One-Shot		●	●	●		●						●	
	AI Servo					●								
	AI Focus	●						●	●	●	●	●		
	AF Point Selection	Auto	●	●	●	●	●	●	○	○	○	○	○	●
		Manual							○	○	○	○	○	
AF-Assist beam	●	●		●		●		●	●	●	●	●	●	
Metering Mode	Single frame	●		●	●		●	●	○	○	○	○	○	
	Continuous		●			●			○	○	○	○	○	
	Self-timer/Remote control	○	○	○	○	○	○	○	○	○	○	○	○	
Flash	Evaluative	●	●	●	●	●	●	●	●	●	●		●	
	Partial								(●)	(●)	(●)	(●)	(●)	
	Centerweighted avg.											●		
Built-in Flash	Auto Firing	●	●		●		●							
	Always Firing								○	○	○	○	○	
Program shift									○					
Exposure Compensation									○	○	○		○	
AE Lock									○	○	○	○	○	
Depth-of-field preview									○	○	○	○	○	
Functions	Date	○	○	○	○	○	○	○	○	○	○	○	○	
	ISO Speed								○	○	○	○	○	
	Red-eye Reduction	○	○		○		○		○	○	○	○	○	
	Beeper	○	○	○	○	○	○	○	○	○	○	○	○	
	Multiple Exposures								○	○	○	○	○	
	AEB								○	○	○	○	○	

● : Set automatically. (●) : Set automatically during AE lock.

○ : User-selectable/settable.

AF Mode

One-Shot AF

When focus is achieved, the exposure setting is set simultaneously and the focus is locked. The shutter cannot be released until focus is achieved.

AI Servo AF

Ideal for moving subjects. The moving subject is focused continuously while the camera predicts the subject's point of focus for when the shutter is released. The exposure is set when the shutter is released.

AI Focus AF

When you press the shutter button, the AF mode (One-Shot AF or AI Servo AF) is set automatically depending on whether the subject is moving or not.

AF Mode and Film Advance Mode

Film Advance Mode	One-Shot AF	AI Servo AF
Single frame	The picture cannot be taken until focus is achieved. When focus is achieved, it also locks at the same time. The evaluative metering's exposure reading is also locked. (The exposure setting is retained until the picture is taken.)	Autofocusing continues to match the subject's movement. The exposure setting is determined at the moment of exposure.
Continuous	The same conditions as above apply during continuous shooting (at about 2.5 frame per second).	The same conditions above apply during continuous shooting. Autofocusing continues during continuous shooting (at about 2.3 frame per second).

Reference

Troubleshooting Guide

If there is a problem, try to resolve it by referring to this Troubleshooting Guide. If the problem still persists, take the camera to your nearest Canon Service Center.

<p>Nothing is displayed on the LCD panel.</p>	<p>The batteries are exhausted.</p> <ul style="list-style-type: none">▶ Replace the batteries with new ones. (→page 14) <p>The batteries have been installed incorrectly.</p> <ul style="list-style-type: none">▶ Install the batteries correctly. (→page 14)
<p>The picture looks blurred.</p>	<p>The lens focus mode is set to <MF> (or <M>).</p> <ul style="list-style-type: none">▶ Set the lens focus mode to <AF>. (→page 16) <p>There was camera shake when the picture was taken.</p> <ul style="list-style-type: none">▶ Hold the camera steady or use a faster shutter speed. (→page 17)
<p>The shutter does not work.</p>	<p>The frame count is not displayed on the LCD panel.</p> <ul style="list-style-type: none">▶ Take out the film and load it correctly. (→page 18) <p>The <☐> icon blinks on the LCD panel.</p> <ul style="list-style-type: none">▶ Replace the batteries with new ones. (→page 14) <p>The <⊙> icon blinks while the rewound film is still in the camera.</p> <ul style="list-style-type: none">▶ Replace with a new roll of film. (→page 18) <p>The focus confirmation light <●> in the viewfinder blinks and focus cannot be achieved.</p> <ul style="list-style-type: none">▶ Select another AF point. (→page 32)If focus still cannot be achieved, focus manually. (→page 34)
<p>The <☐> icon blinks on the LCD panel.</p>	<p>The battery level is very low.</p> <ul style="list-style-type: none">▶ Replace the batteries with new ones. (→page 14) <p>A misoperation has occurred.</p> <ul style="list-style-type: none">▶ Press the shutter button halfway. (→page 17)▶ Remove the batteries and reload it. (→page 14) <p>If the blinking <☐> icon does not turn off, consult your nearest Canon Service Center.</p>

- ⓘ When using an external flash unit, an EOS-dedicated Speedlite is recommended. Using the camera with a flash unit (equipped with electrical contacts on the hot shoe foot), high-voltage flash unit, or flash accessories dedicated to a different brand may result in camera misoperation or malfunction.

Major Specifications

• Type

Type	35 mm AF/AE SLR camera with built-in winder and flash
Recording media	35 mm film
Image size	24 x 36 mm
Compatible lenses	Canon EF lenses
Lens mount	Canon EF mount (electronic data exchange)

• Viewfinder

Type	Eye-level pentamirror
Coverage	90% vertically and horizontally
Magnification	0.7x (-1 diopter with 50mm lens at infinity)
Eyepoint	18.5 mm
Dioptric adjustment range	-2.5 - +0.5 diopter
Focusing screen	Fixed (New Laser Matte screen)
Mirror	Quick-return half mirror (Transmission: reflection rate of 40:60, No mirror cut-off with EF 300mm f/2.8L plus Extender 2x or shorter lens)
Viewfinder information	AF (superimposed AF point, focus confirmation light); Exposure (shutter speed, aperture, exposure level, exposure warning, AE lock); Flash (flash ready, hi-speed sync, FE lock, red-eye reduction, out of working range warning)
Depth-of-field preview	Depth-of-field preview button

• Autofocus

Type	TTL-CT-SIR with a CMOS (Complementary Metal Oxide Semiconductor) sensor
AF points	7 AF points
AF working range	EV 1 - 18 (ISO 100)
Focusing modes	One-Shot AF, AI Servo AF, AI Focus AF, manual focusing (MF)
AF point selection	Automatic/manual
Selected AF point display	Super-imposed AF point in viewfinder and also indicated on LCD panel.
AF-assist beam	Intermittent firing of built-in flash Working distance: Approx. 4 m/13.1 ft at center, Approx. 3.5 m/11.5 ft at outer edge

• Exposure control

Exposure metering modes	TTL full aperture metering with 35-zone SPC <ol style="list-style-type: none">1. Evaluative metering (linkable to any AF point)2. Partial metering (Automatically set with AE lock, approx. 9.5 % of viewfinder at the center.)3. Center-weighted average metering (automatically set in manual exposure mode)
Metering range	EV 1 - 20 (normal temperature, 50mm f/1.4, ISO 100)
Exposure control	Full auto, six programmed image control modes (portrait, landscape, close-up, sports, night portrait, flash off), Program AE (shiftable), shutter-priority AE, aperture-priority AE, automatic depth-of-field AE, E-TTL/A-TTL/TTL program autoflash, manual exposure
Film speeds	ISO 6 - 6400 (Set automatically for DX-coded film within ISO 25 - 5000 in 1/3-stop increments)

Reference

Exposure compensation	Manual exposure compensation: +/- 2 stops in 1/2-stop increments (can be used with AEB) Auto Exposure Bracketing (AEB): +/- 2 stops in 1/2-stop increments
AE lock	Auto AE lock: Operates in One-shot AF mode with evaluative metering when focus is achieved Manual AE lock: By AE lock button in partial metering mode
Multiple exposures	Max. 9 exposures

• Shutter

Type	Electronically controlled focal-plane shutter
Shutter speeds	1/2000 - 30 sec. in 1/2-stop increments, bulb, X sync at 1/90 sec.
Shutter release	Soft touch electromagnetic release
Self-timer	Shoot after 10 sec. delay
Remote control	Remote Switch RS-60E3, Remote Controller RC-1/RC-5 (DATE Model only)

• Flash

Built-in flash	AF point-linked, 3-zone autofocus Guide No. 12 (ISO 100, meters), 39 (ISO 100, feet) Recycling time: Approx. 2 sec. Flash coverage: 28 mm lens angle covered Red-eye reduction: Lamp
----------------------	--

External

EOS-dedicated flash	E-TTL / A-TTL / TTL autofocus
---------------------------	-------------------------------

• Film transport

Film loading	Automatic prewind
Film advance modes	Single-frame/continuous shooting
Continuous shooting speeds	ONE-SHOT AF: Approx. 2.5 fps AI SERVO AF: Approx. 2.3 fps
Frame counter	Subtractive
Film rewind	Automatic. Mid-roll rewind
Prewind time	Approx. 7 sec. (24-ex. film)
Noise level	Approx. 54 dB

• Date imprinting (DATE Model only)

Automatic dating	Automatic calendar to 2099
Power source	Uses camera power

• Power source

Power source	Two CR2 lithium batteries
Battery life	(→page 15)
Battery check	Automatic

• Dimensions

(W x H x D) 130 x 88 x 64 mm/5.1 x 3.5 x 2.5 in

• **Weight** 365 g/12.9 oz (body only, excluding batteries)

- All the specifications above are based on Canon's testing and measuring standards.
- Specifications and physical appearance are subject to change without notice.

Index

A	AEB.....	46	unloading.....	19
	AE lock.....	44	midroll rewind.....	20
	AF.....	16	setting ISO speed manually.....	50
	AF-assist beam.....	23	ISO speed.....	52
	AF mode.....	55	Flash.....	23
	AF point.....	32	Focus lock.....	33
	AI Focus AF.....	55	Full Auto mode.....	22
	AI Servo AF.....	55	H Holding the camera.....	20
	Aperture.....	52	L LCD panel.....	10
B	Basic Zone.....	12, 21	illumination.....	51
	Batteries.....	14	Lens mounting / detaching.....	16
	Beeper.....	51	M Manual focusing.....	34
	Built-in flash.....	49	Metering modes.....	35
	Bulb exposures.....	47	Multiple exposures.....	48
C	Command Dial.....	12	O One-Shot AF.....	55
	Continuous shooting.....	35	P Program AE.....	36
	Creative Zone.....	12, 31	Programmed Image Control Modes.....	24
D	Date/time.....	29	R Red-eye reduction.....	26
	Depth-of-field AE.....	41, 52	Remote switch.....	51
	Dioptric adjustment.....	9	S Self-timer.....	27
E	Eye-piece cover.....	28	Shutter button.....	17
	Exposure.....	52	pressing halfway.....	17
	Exposure compensation.....	45	pressing fully.....	17
F	Feature Availability Table.....	54	Shutter speed.....	52
	Film.....		Single-frame shooting.....	35
	loading.....	18	Superimpose.....	11
			V Viewfinder information.....	11
			W Wireless remote control.....	28

This device complies with Part 15 of the FCC Rules. Operation is subject to the following two conditions: (1) This device may not cause harmful interference, and (2) this device must accept any interference received, including interference that may cause undesired operation.

Do not make any changes or modifications to the equipment unless otherwise specified in the instructions. If such changes or modifications should be made, you could be required to stop operation of the equipment.

This equipment has been tested and found to comply with the limits for a class B digital device, pursuant to part 15 of the FCC Rules. These limits are designed to provide reasonable protection against harmful interference in a residential installation. This equipment generates, uses and can radiate radio frequency energy and, if not installed and used in accordance with the instructions, may cause harmful interference to radio communications.

However, there is no guarantee that interference will not occur in a particular installation. If this equipment does cause harmful interference to radio or television reception, which can be determined by turning the equipment off and on, the user is encouraged to try to correct the interference by one or more of the following measures:

- Reorient or relocate the receiving antenna.
- Increase the separation between the equipment and receiver.
- Consult the dealer or an experienced radio/TV technician for help.

This digital apparatus does not exceed the Class B limits for radio noise emissions from digital apparatus as set out in the interference-causing equipment standard entitled "Digital Apparatus", ICES-003 of the Industry Canada.



The CE Mark is a Directive conformity mark of the European Community (EC)